

**Series 8, Built-in microwave oven,
Black
BFL7221B1B**

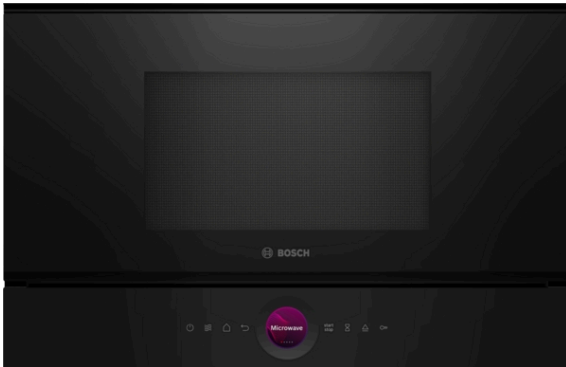

The compact microwave 38cm. Inverter Technology: constant microwave power for heating food gradually. Microwave Boost Function: quick and easy warming.

- **Digital Control Ring:** the simple and innovative way to select oven settings.
- **TFT Touch Display:** easy control thanks to an innovative Digital Control Ring and TFT touchscreen.
- **AutoPilot 7:** every dish is a perfect success thanks to 7 pre-set automatic programmes.
- **Microwave Boost Function:** quick and easy warming.
- **Red LCD display control:** easy-to-use thanks to direct access to additional functions, temperature recommendation and temperature indication.

Technical Data

Type of micro-wave oven : MW only
Type of control : Electronic
Color / Material Front : Black
Dimensions : 382 x 594 x 318 mm
Cavity dimensions : 230 x 350 x 270 mm
Length of electrical supply cord : 175.0 cm
Net weight : 17.0 kg
Gross weight : 18.9 kg
EAN code : 4242005322671
Maximum micro-wave power : 900 W
Connection rating : 1220 W
Fuse protection : 10 A
Voltage : 220-240 V
Frequency : 50; 60 Hz
Plug type : GB plug
Cavity dimensions : 230 x 350 x 270 mm



4 242005 322671

Series 8, Built-in microwave oven, Black BFL7221B1B

The compact microwave 38cm. Inverter Technology: constant microwave power for heating food gradually. Microwave Boost Function: quick and easy warming.

Performance/technical information

- Appliance dimension (hxwx): 382 mm x 594 mm x 318 mm
- Niche dimension (hxwx): 362 mm - 380 mm x 560 mm - 568 mm x 300 mm
- Please refer to the dimensions provided in the installation manual

Features

- 900 W maximum microwave power and the following options 180 W, 360 W, 600 W, 90 W, 900 W
- Intelligent microwave inverter technology: For optimised results maximum output power will be regulated to 600 W when used in longer operation for gentler cooking.
- Cavity volume: 21 l

Design

- stainless steel, Glass base cavity with Glass base, stainless steel

Cleaning

- hydrolyse program

Programmes/functions

- Electronic clock timer
- Touch controls
- User-friendly electronics: extremely easy and comfortable operation
- AutoPilot, 7
- 3 defrost and 4 cooking programmes in microwave function
- Quick Start Button: one tap to maximum microwave power for 30 seconds
- LED light
- Side opening door, left hinged
- Electronic open button
- Touch key operation

Features

- Start button
Door contact switch
- Integral cooling fan

Technical information

- Total connected load electric: 1.22 KW
- Nominal voltage: 220 - 240 V
- For installation into a 60 cm wide wall unit, installation in tall housing

Series 8, Built-in microwave oven, Black BFL7221B1B

measurements in mm

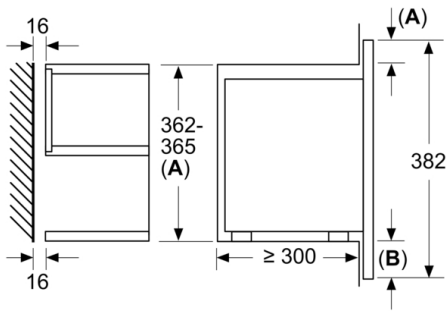

- A:** Overhang at top:
 Recess 362: 6 mm
 Recess 365: 3 mm
B: Overhang at bottom: 14 mm

Measurements in mm

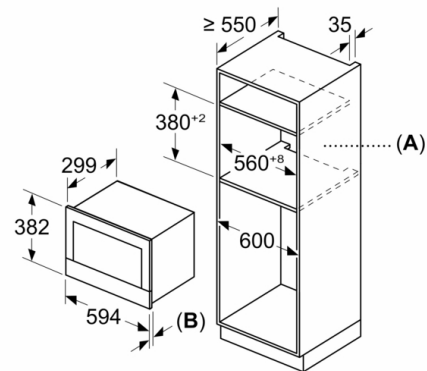

- A:** Back wall open
B: 19.5 mm

Measurements in mm

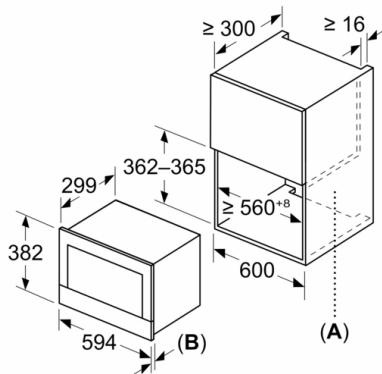

- A:** Back wall open
B: 19.5 mm